

3K 3307 VIO / HT VIO

HAMMTRONIC



OSCILLATION



Compactor with vibration and oscillation

- ▶ Ergonomic driver's compartment for perfect all-round visibility
- ▶ Convenient information display
- ▶ Hammtronic - electronic machine management
- ▶ Infinitely variable hydrostatic all-wheel drive
- ▶ Great engine performance with traction control
- ▶ High climbing power through automatic slip control
- ▶ 3-point swivel joint for highest driving comfort
- ▶ Hydrostatic steering
- ▶ Very easy maintenance, long service intervals



3307 VIO / 3307 HT VIO



TECHNICAL DATA

3307 VIO

3307 HT VIO

Weights			
Operating weight	kg	6370	6370
Maximum weight	kg	7800	7800
Axle load, front/rear	kg	3490/2880	3490/2880
Load per tire, rear	kg	1440	1440
Static linear load, front	kg/cm	20,8	20,8
Machine dimensions			
Max. working width	mm	1680	1680
Turning radius, inside	mm	3060	3060
Size of tires, rear		AW 14.9-24 8 TL	AW 14.9-24 8 TL
Diesel engine			
Manufacturer		DEUTZ	DEUTZ
Type		BF4M 2011	BF4M 2011
Number of cylinders		4	4
Power rat. DIN/ISO3046IFN kW/PS/rpm		65,0/88,4/2800	65,0/88,4/2800
Power rating SAE J1349, kW/HP/rpm		65,0/87,1/2800	65,0/87,1/2800
Drive			
Hydrostatic drive, front/rear		Hydraulic motor/axle	Hydraulic motor/axle
Regulation, infinitely variable			Hammtronic/manual
Speed, infinitely variable	km/h		0-12,5
Speed, working gear	km/h	0-4,4/0-6,3/0-6,7	
Speed, transportation gear	km/h	0-12,5	
Climbing ability, vibration on/off	%	54/59	57/62
Vibration system			
Hydrostatic drive			
Vibration			
Vibration frequency	Hz	36	36
Amplitude, vibration	mm	1,38	1,38
Centrifugal force, vibr.	kN	123	123
Oscillation			
Oscillation frequency	Hz	36	36
Tangential amplitude, oscillation	mm	1,37	1,37
Oscillation force	kN	123	123
Steering			
Steering, type		Pivoted steering	Pivoted steering
Steering, actuation		hydrostatic, steer. wheel	hydrostatic, steer. wheel
Steering lock +/-	Grad	35	35
Oscillation angle +/-	Grad	10	10
Brake system			
Service brake, mode of action		hydrostatic	hydrostatic
Service brake, actuation		Drive lever	Drive lever
Parking brake, mode of action		Spring-loaded/mechanical	Spring-loaded/mechanical
Parking brake, actuation		electr. a. autom.	electr. a. autom.
Emergency brake, mode of action		hydr./mech.	hydr./mech.
Emergency brake, actuation		Emergency stop	Emergency stop
Equipment			
Suspended driving position, access from both sides. Sliding and swivelling seat console. 2 multifunctional drive levers. Traction control. Swivelling drive and dashboard console. Modern information and control display. Sound insulation. Tilttable GFK-engine hood. CE-conformity.			
Optional			
Comfortable ROPS cabin with panoramic view. Working lights, wipers front/rear, exterior and interior mirrors. Radio. Heating with dust free ventilation. Air conditioning. ROPS/FOPS. Sun top. HCQ-Indicator, HCQ-Printer, HCQ-GPS-Navigator. Tachograph. Lighting according to German Road Regulation. Special paint.			

Further data on request / subject to change

3307 VIO - Compactor with vibration and oscillation
3307 HT VIO - Compactor with vibration, oscillation, Hammtronic

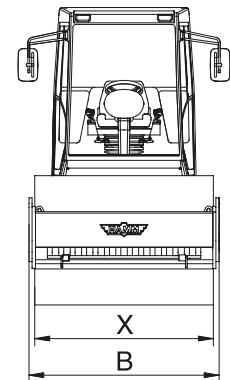
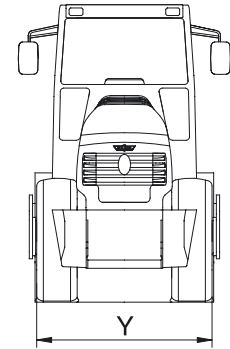
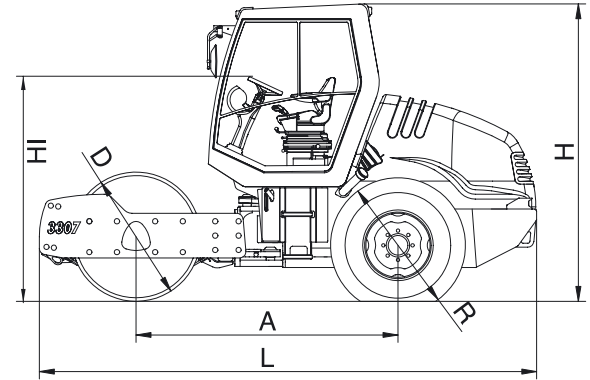

		3307 VIO	3307 HT VIO
Total length	L	4680	4680
Total width	B	2100	2100
Total height	H	2790	2790
Wheel base	A	2465	2465
Roller drum width	X	1680	1680
Drum diameter	D	1216	1216
Width over tires	Y	1650	1650
Diameter of tires	R	1280	1280
High loading, min.	HI	2110	2110