

3K 3518 / 3518 P HT

HAMMTRONIC



Vibratory compactor with Hammtronic

- ▶ Ergonomic driver's compartment for perfect all-round visibility
- ▶ Convenient information display
- ▶ Hammtronic - electronic machine management
- ▶ Infinitely variable hydrostatic all-wheel drive
- ▶ Great engine performance with traction control
- ▶ High climbing power through automatic slip control
- ▶ 3-point swivel joint for highest driving comfort
- ▶ Hydrostatic steering
- ▶ Very easy maintenance, long service intervals



3518 HT / 3518 HT P



TECHNICAL DATA

3518 HT

3518 HT P

Weights			
Operating weight	kg	17825	18025
Maximum weight	kg	20000	20000
Axle load, front/rear	kg	10785/7040	10985/7040
Load per tire, rear	kg	3520	3520
Static linear load, front	kg/cm	48,6	
Machine dimensions			
Max. working width	mm	2220	2220
Turning radius, inside	mm	4180	4180
Padfoot, number			150
Height of the padfoot	mm		100
Front area of padfoot			152
Size of tires, rear		AW 23.1-26 12 PR	TR 23.1-26 12 PR
Diesel engine			
Manufacturer		DEUTZ	DEUTZ
Type		TCD 2012 L06 2V	TCD 2012 L06 2V
Number of cylinders		6	6
Power rat. ISO 14396, kW/PS/rpm		155,0/210,8/2300	155,0/210,8/2300
Power rating SAE J1349, kW/HP/rpm		155,0/207,7/2300	155,0/207,7/2300
Drive			
Hydrostatic drive, front/rear		Hydraulic motor/axle	Hydraulic motor/axle
Regulation, infinitely variable		Hammtronic/manual	Hammtronic/manual
Speed, infinitely variable	km/h	0 - 11,4	0 - 11,1
Climbing ability, vibration on/off	%	55/60	65/70
Vibration system			
Hydrostatic drive			
Vibration			
Vibration frequency, front, l/l	Hz	27/30	27/30
Amplitude, front, l/l	mm	2,00/1,19	1,93/1,15
Centrifugal force, front, l/l	kN	331/243	331/243
Steering			
Steering, type		Pivoted steering	Pivoted steering
Steering, actuation		hydrostatic, steer. wheel	hydrostatic, steer. wheel
Steering lock +/-	Grad	32	32
Oscillation angle +/-	Grad	10	10
Brake system			
Service brake, mode of action		hydrostatic	hydrostatic
Service brake, actuation		Drive lever	Drive lever
Parking brake, mode of action		Spring-loaded/mechanical	Spring-loaded/mechanical
Parking brake, actuation		electr. a. autom.	electr. a. autom.
Emergency brake, mode of action		hydr./mech.	hydr./mech.
Emergency brake, actuation		Emergency stop	Emergency stop
Equipment			
Suspended driving position, access from both sides. Sliding and swivelling seat console. 2 multifunctional drive levers. Traction control system. Engine management. Velocity pre-selection. Frequency control. Swivelling drive and dashboard console. Modern information and control display. Sound insulation. Tilttable GFK-engine hood. CE-conformity.			
Optional			
Comfortable ROPS cabin with panoramic view. Working lights, wipers front/rear, exterior and interior mirrors. Radio. Heating with dust free ventilation. Air conditioning. ROPS/FOPS. Sun top. HCQ-Indicator, HCQ-Printer, HCQ-GPS-Navigator. Tachograph. Lighting according to German Road Regulation. Special paint.			

Further data on request / subject to change

3518 HT - Vibratory compactor with Hammtronic
3518 HT P - Padfoot compactor with Hammtronic

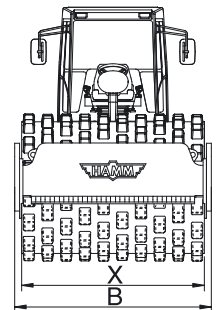
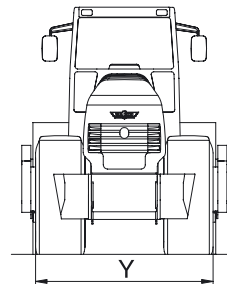
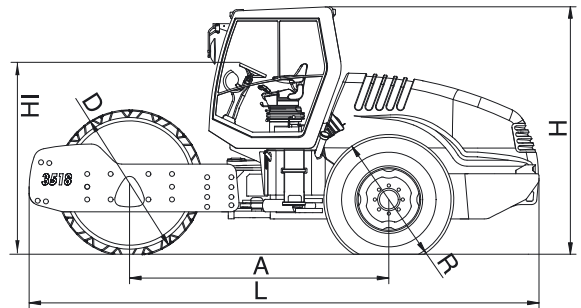
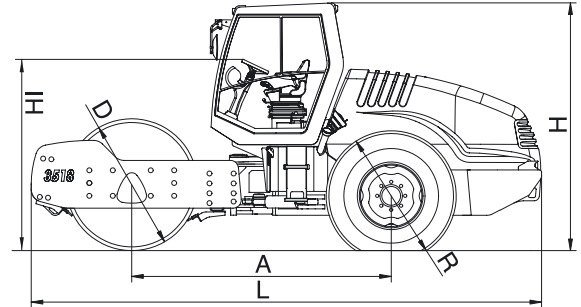

		3518 HT	3518 HT P
Total length	L	6210	6210
Total width	B	2390	2390
Total height	H	2990	2990
Wheel base	A	3165	3165
Roller drum width	X	2220	2220
Drum diameter	D	1600	1784
Width over tires	Y	2130	2130
Diameter of tires	R	1565	1565
High loading, min.	HI	2320	2320