

HD 14 TT



Pneumatic tyred roller

- ▶ Optimal view due to concave front end
- ▶ Excellent view to the drum edges
- ▶ Ergonomic driver's platform, low working platform
- ▶ Modern instrument panel
- ▶ Low machine height
- ▶ 3-point swivel joint for outstanding driving comfort
- ▶ Crab steering
- ▶ Central suspension point
- ▶ Very easy maintenance, long service intervals

TECHNICAL DATA

HD 14 TT

Weights	
Operating weight	kg 3400
Maximum weight	kg 4300
Axle load, front/rear	kg 1620/1780
Load per tire, front/rear	kg 540/445
Machine dimensions	
Max. working width	mm 1276
Turning radius, inside	mm 2602
Size of tires, front/rear	10.5/80-16
Diesel engine	
Manufacturer	HATZ
Type	4W35T
Number of cylinders	4
Power rat. DIN/ISO3046IFN kW/PS/rpm	29,4/40,0/2800
Power rating SAE J1349, kW/HP/rpm	29,4/39,4/2800
Drive	
Hydrostatic drive, front/rear	Hydr. motor/hydr. motor
Speed, infinitely variable	km/h 0-11,9
Climbing ability	% 40
Steering	
Steering, type	Pivoted steering
Steering, actuation	hydrostatic, steer. wheel
Steering lock +/-	Grad 33
Oscillation angle +/-	Grad 8
Brake system	
Service brake, mode of action	hydrostatic
Service brake, actuation	Drive lever
Parking brake, mode of action	Spring-loaded/mechanical
Parking brake, actuation	electr. a. autom.
Emergency brake, mode of action	hydr./mech.
Emergency brake, actuation	Emergency stop
Sprinkler system	
Water sprinkler, type	Pressure
Actuation, sprinkling	interval/manual
Water tank, capacity	Ltr. 290
Equipment	
50 mm crab steering, suspended driver seat, comfort seat with safety belt, 2 multifunctional control levers, hour meter, pilot lamps and emergency stop device, CE-conformity.	

Optional
Lighting according to German Road Regulation, 2 working lamps on ROPS, backup alarm, rotating beacon, special paint, sun top, ROPS, super noise insulation.

Further data on request / subject to change

HD 14 TT - Pneumatic tyred roller

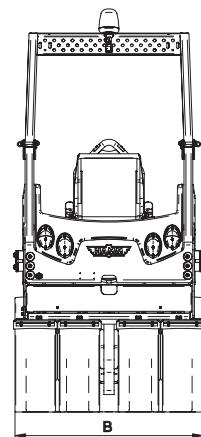
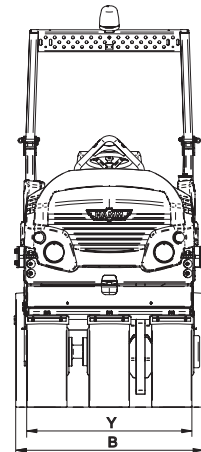
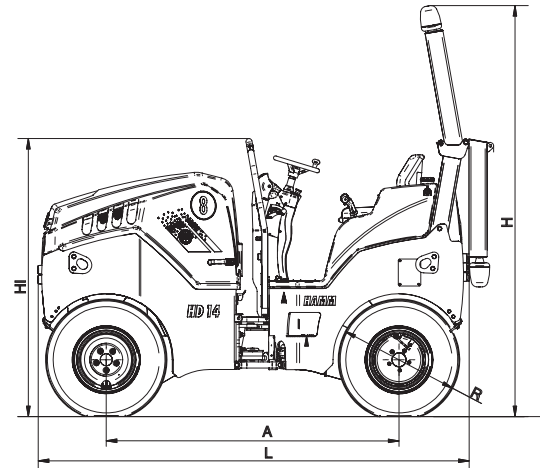

	HD 14 TT	
Total length	L	2856
Width	B	1296
Total height	H	2575
Wheel base	A	1950
Width over tires	Y	1127
Diameter of tires	R	810
Height loading, min.	HI	1853