

HD 110 / 110 K

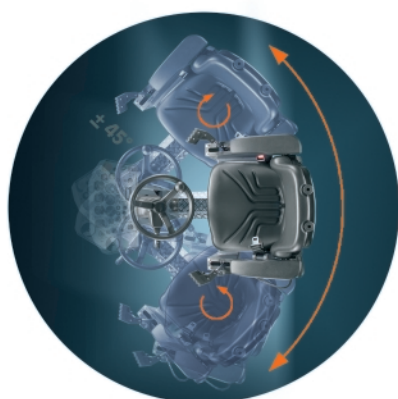

Articulated tandem roller

- ▶ Ergonomic driver's seat with 2 multifunction control lever
- ▶ Driver's seat including steering wheel and instrument panel rotatable and pivotable
- ▶ Outstanding visibility to the surface and edge of the drum and surroundings
- ▶ Crab steering to extend the working with
- ▶ Hydrostatic all-wheel drive ensures great climbing pave
- ▶ Turbo-Diesel with high performance and low noise
- ▶ Sprinkler system with 2 water pumps, spraying jets visible from the driver's seat



HD 110 / HD 110K



TECHNICAL DATA

HD 110

HD 110K

| Weights | | | |
|------------------------------------------|-------|---------------------------|---------------------------|
| Operating weight | kg | 10540 | 9225 |
| Maximum weight | kg | 13300 | 12000 |
| Axle load, front/rear | kg | 5300/5240 | 5290/3935 |
| Load per tire, rear | kg | | 983,75 |
| Static linear load, front/rear | kg/cm | 31,5/31,2 | |
| Static linear load, front | kg/cm | | 31,5 |
| Machine dimensions | | | |
| Max. working width | mm | 1780 | 1750 |
| Turning radius, inside | mm | 3961 | 3961 |
| Size of tires, rear | | | 11.00-20 |
| Diesel engine | | | |
| Manufacturer | | DEUTZ | DEUTZ |
| Type | | TCD 2012 L04 2V | TCD 2012 L04 2V |
| Number of cylinders | | 4 | 4 |
| Power rat. ISO 14396, kW/PS/rpm | | 100,0/136,0/2300 | 100,0/136,0/2300 |
| Power rating SAE J1349, kW/HP/rpm | | 100,0/134,0/2300 | 100,0/134,0/2300 |
| Drive | | | |
| Hydrostatic drive, front/rear | | Hydr. motor/hydr. motor | Hydr. motor/hydr. motor |
| Speed, working gear | km/h | 0-7,4 | 0-7,4 |
| Speed, transportation gear | km/h | 0-14,8 | 0-14,8 |
| Climbing ability, vibration on/off | % | 30/40 | 30/40 |
| Vibration system | | | |
| Hydrostatic drive, double drum vibration | | | |
| Vibration | | | |
| Vibration frequency, front, I/II | Hz | 42/50 | 42/50 |
| Vibration frequency, rear, I/II | Hz | 42/50 | |
| Amplitude, front, I/II | mm | 0,81/0,47 | 0,81/0,47 |
| Amplitude, rear, I/II | mm | 0,81/0,47 | |
| Centrifugal force, front, I/II | kN | 117/97 | 117/97 |
| Centrifugal force, rear, I/II | kN | 117/97 | |
| Steering | | | |
| Steering, type | | Pivoted steering | Pivoted steering |
| Steering, actuation | | hydrostatic, steer. wheel | hydrostatic, steer. wheel |
| Steering lock +/- | Grad | 39 | 39 |
| Oscillation angle +/- | Grad | 10 | 10 |
| Brake system | | | |
| Service brake, mode of action | | hydrostatic | hydrostatic |
| Service brake, actuation | | Drive lever | Drive lever |
| Parking brake, mode of action | | Spring-loaded/mechanical | Spring-loaded/mechanical |
| Parking brake, actuation | | electr. a. autom. | electr. a. autom. |
| Emergency brake, mode of action | | hydr./mech. | hydr./mech. |
| Emergency brake, actuation | | Emergency stop | Emergency stop |
| Sprinkler system | | | |
| Water sprinkler, type | | Pressure | Pressure |
| Actuation, sprinkling | | interval/manual | interval/manual |
| Water tank, capacity | Ltr. | 900 | 900 |
| Additive sprinkling, type | | | Pressure |
| Actuation, additive sprinkling | | | Push button |
| Additive tank, capacity | Ltr. | | 22 |

Equipment

Spring loaded driving position, 1 swivelling and turning driver seat, 2 multifunctional levers, left and right at seat. Indicators for: engine temperature, working hours, fuel tank, control lights and emergency stop button, 2 working lights rear, main battery switch, triple oil filter, indicators for: hydraulic oil temperature, water level. CE prepared.

Optional

Panoramic ROPS cabin with: heating, dust-free ventilation, sun shade, interior lighting, front and rear wipers, interior mirror, beacon, lighting according to German Road Regulation, ROPS/FOPS, safety belt, speedometer, sound insulation, sun top, pressing and cutting equipment, radio, special paint, sponge roll, bitumen temperature gauge, back-up alarm, adjustable vibration: front/rear/double.

Further data on request / subject to change

HD 110 - Articulated tandem roller
HD 110K - Articulated combination tandem roller

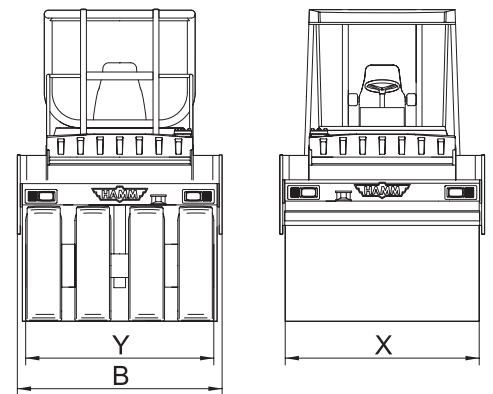
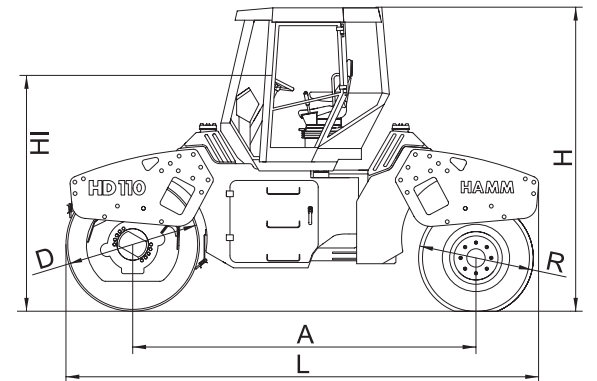
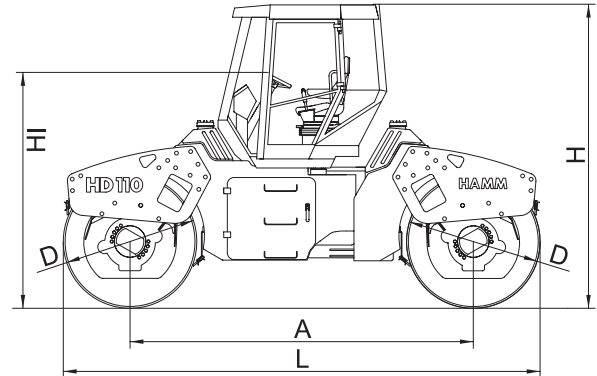

| | | HD 110 | HD 110K |
|--------------------|----|--------|---------|
| Total length | L | 4600 | 4600 |
| Total width | B | 1810 | 1810 |
| Total height | H | 3040 | 3040 |
| Wheel base | A | 3400 | 3400 |
| Roller drum width | X | 1680 | 1680 |
| Drum diameter | D | 1200 | 1200 |
| Width over tires | Y | | 1620 |
| Diameter of tires | R | | 1030 |
| High loading, min. | HI | 2360 | 2360 |