

HD 70 / 70 K

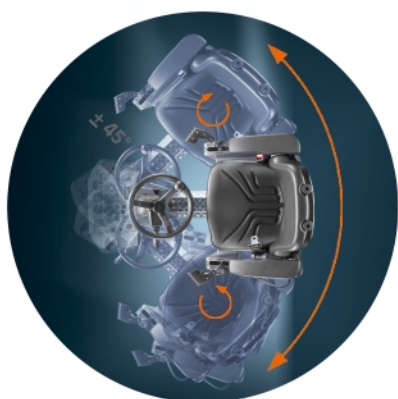

Articulated tandem roller

- ▶ Ergonomic driver's seat with 2 multifunction control levers
- ▶ Driver's seat including steering wheel and instrument panel rotatable and pivotable
- ▶ Outstanding visibility to the surface and edge of the drum and surroundings
- ▶ Crab steering to extend the working width
- ▶ Hydrostatic all-wheel drive ensures great climbing pave
- ▶ Turbo-Diesel with high performance and low noise
- ▶ Sprinkler system with 2 water pumps, spraying jets visible from the driver's seat



HD 70 / HD 70K



TECHNICAL DATA

HD 70

HD 70K

Weights		HD 70	HD 70K
Operating weight	kg	7265	6970
Maximum weight	kg	9900	10000
Axle load, front/rear	kg	3675/3590	3685/3285
Load per tire, rear	kg		821,25
Static linear load, front/rear	kg/cm	24,5/23,9	
Static linear load, front	kg/cm		24,6
Machine dimensions			
Max. working width	mm	1600	1570
Turning radius, inside	mm	4174	4174
Size of tires, rear			11.00-20
Diesel engine			
Manufacturer		DEUTZ	DEUTZ
Type		BF4M 2011	BF4M 2011
Number of cylinders		4	4
Power rat. DIN/ISO3046IFN kW/PS/rpm		60,0/81,6/2500	60,0/81,6/2500
Power rating SAE J1349, kW/HP/rpm		60,0/80,4/2500	60,0/80,4/2500
Drive			
Hydrostatic drive, front/rear		Hydr. motor/hydr. motor	Hydr. motor/hydr. motor
Speed, working gear	km/h	0-6,3	0-6,3
Speed, transportation gear	km/h	0-12,6	0-12,6
Climbing ability, vibration on/off	%	30/40	30/40
Vibration system			
Hydrostatic drive, double drum vibration			
Vibration			
Vibration frequency, front, I/II	Hz	48/58	48/58
Vibration frequency, rear, I/II	Hz	48/58	
Amplitude, front, I/II	mm	0,62/0,35	0,62/0,35
Amplitude, rear, I/II	mm	0,62/0,35	
Centrifugal force, front, I/II	kN	76/62	76/62
Centrifugal force, rear, I/II	kN	76/62	
Steering			
Steering, type		Pivoted steering	Pivoted steering
Steering, actuation		hydrostatic, steer. wheel	hydrostatic, steer. wheel
Steering lock +/-	Grad	36	36
Oscillation angle +/-	Grad	10	10
Brake system			
Service brake, mode of action		hydrostatic	hydrostatic
Service brake, actuation		Drive lever	Drive lever
Parking brake, mode of action		Spring-loaded/mechanical	Spring-loaded/mechanical
Parking brake, actuation		electr. a. autom.	electr. a. autom.
Emergency brake, mode of action		hydr./mech.	hydr./mech.
Emergency brake, actuation		Emergency stop	Emergency stop
Sprinkler system			
Water sprinkler, type		Pressure	Pressure
Actuation, sprinkling		interval/manual	interval/manual
Water tank, capacity	Ltr.	720	720
Additive sprinkling, type			Pressure
Actuation, additive sprinkling			Push button
Additive tank, capacity	Ltr.		11

Equipment
Spring loaded driving stand, 1 swivelling and turning driver seat, 2 multifunctional levers, left and right at seat. Indicators for: engine temperature, working hours, fuel tank, control lights and emergency stop button, 2 working lights rear, main battery switch, triple oil filter. Indicators for: hydraulic temperature, water level in tanks. CE-conformity.

Optional

Panoramic ROPS cabin with: heating, dust-free ventilation, sun shade, interior lighting, front and rear wipers, interior mirror, beacon, lightings according to German Road Regulations, ROPS/FOPS, HCQ-Indicator Asphalt, safety belt, speedometer, noise isolation, sun top, pressing and cutting equipment, radio, special paint, sponge roll, bitumen-temperature gauge, back-up alarm, adjustable vibration: front/rear/double.

Further data on request / subject to change

HD 70 - Articulated tandem roller
HD 70K - Articulated combination tandem roller

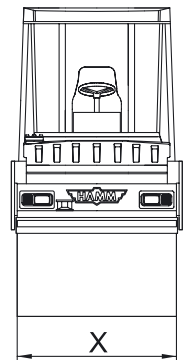
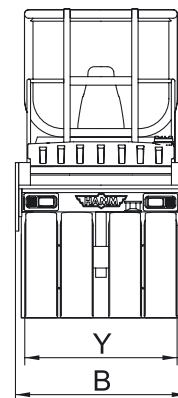
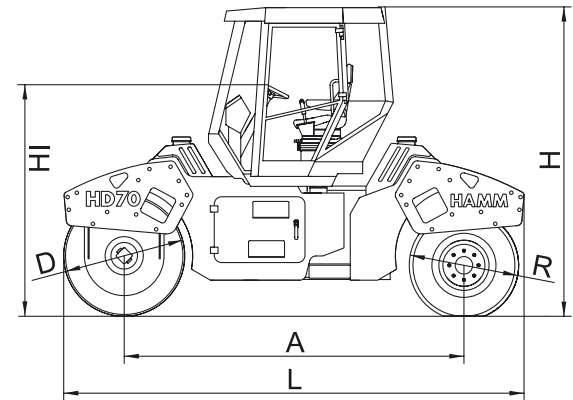
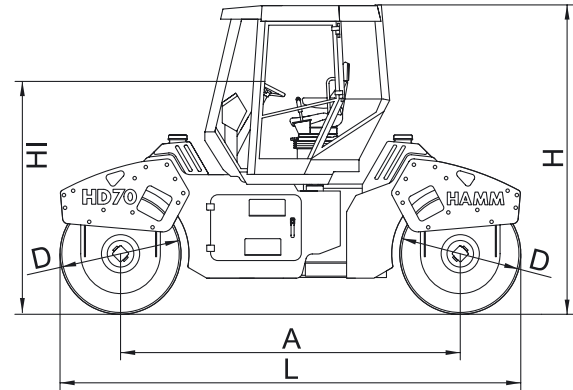

		HD 70	HD 70K
Total length	L	4340	4340
Total width	B	1610	1610
Total height	H	2940	2940
Wheel base	A	3200	3200
Roller drum width	X	1500	1500
Drum diameter	D	1140	1140
Width over tires	Y		1435
Diameter of tires	R		1030
High loading, min.	HI	2260	2260